

\* Units of weights and measures shall be expressed in terms of the metric system ( kg & mm )

OVER VIEW	<ul style="list-style-type: none"> <li>Testing components fold and slide samples.</li> <li>Can set samples to 4 lanes in various folding radius.</li> <li>Sliding stroke and operating speed are all the same.</li> <li>Can adjust folding radius with the position of Clamp, fixing side.</li> </ul>
SPECIFICATION of TEST CONDITION	<ul style="list-style-type: none"> <li>Thickness of sample : max. 3 mm (adjustable in every lane)</li> <li>Width of sample : max. 52 mm (adjustable in every lane)</li> <li>Folding radius : 0~55 mm (adjustable in every lane)                             <ul style="list-style-type: none"> <li>Can't set radius less than Thickness of sample + 5" when use clamps (accessories).</li> <li>Set samples on each sides with adhesive tape (without clamp bar) when screws interfere it.</li> </ul> </li> <li>Sliding stroke : 0~±60 mm (all the same)</li> <li>Operating Speed : 10~90 r/min (all the same)</li> <li>Electric Insulation : Samples are insulated from Test Jig (exclude bars and screws).</li> </ul> <p>* In addition, refer to an attached sheet for the detail of DMLHB.</p>
INSTALLATION ENVIRONMENT	<ul style="list-style-type: none"> <li>Temp. : +5~+40°C (41~104°F)</li> <li>Humi. : 15~ 85%RH (No Condensation)</li> </ul>
MASS	<ul style="list-style-type: none"> <li>Testing Machine : about 17 kg (about 37.5 lb)</li> <li>Test Jig : about 9 kg (about 20.0 lb)</li> <li>Cover, test Jig : about 4 kg (about 9.0 lb)</li> </ul>
NOTE	<ul style="list-style-type: none"> <li>Tool to set up is only hexagon bar wrench (3 mm)</li> </ul>

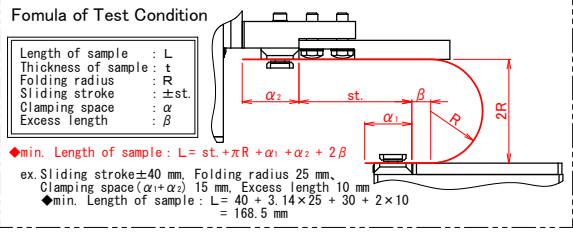
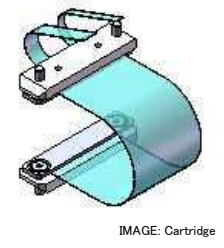
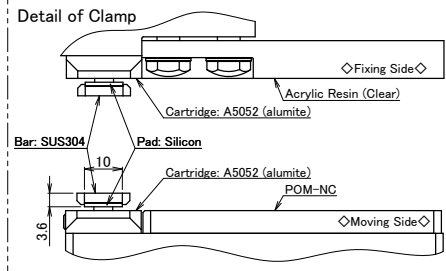

- ◇Standard Components and Accessories
- ET221001A0001 : Test Jig Sliding Folding "4"
  - ET136001A0001 : Floating Joint
  - ET209008A0001 : Joint Bracket
  - ET503004A0003 : Safety Cover

材質 MATERIAL	質量 MASS	第3角法 THRD ANGLE PROJECTION	尺 SCALE	TITLE
表面処理 SURFACE PROCESSING	熱処理 HEAT TREATMENT	作成日付 DATE	承認 APPROVED	名 Desktop Mdel Endurance Testing Machine DMLHB
		承認 DATE	設計 DESIGNED	称 Test Jig, Sliding Folding (4 Lanes)
		検閲 CHECKED	設計 DESIGNED	番 ET221001S0001-0